



ACCU-TECH, INC.

43718 Utica Road
Sterling Heights, MI - Phone: 586.323.1181
www.accutechmeasurement.com

Location of the **FULL LAYOUT MEASUREMENT FEATURES** on the part.

Customer: YOUR CUSTOMER NAME (YOUR COMPANY NAME)

Part Name: PART NAME INSERTED HERE

Part #: PART # INSERTED HERE

Job #: **YOUR JOB # HERE**

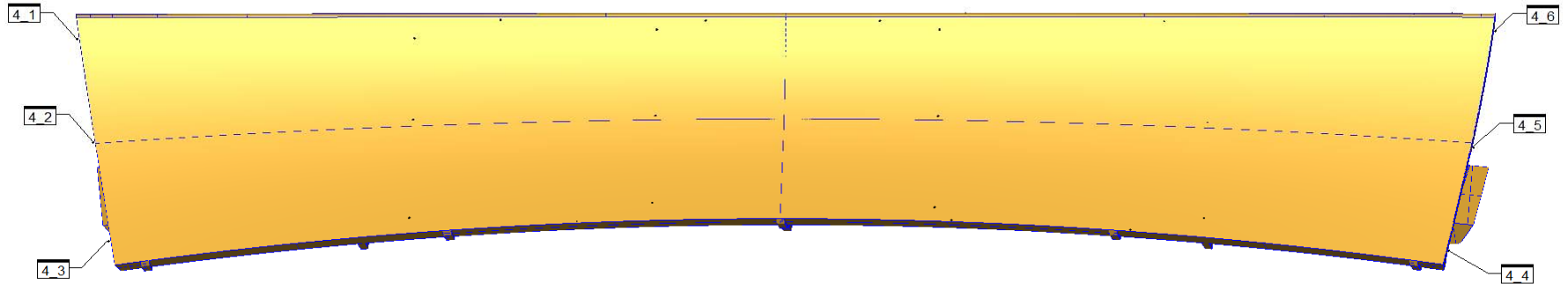

"A Revolution in the Dimensional Inspection Service Industry."

ISO 17025-2005 Certified - A2LA Accredited Laboratory



ACCU-TECH, INC.

43718 Utica Road
Sterling Heights, MI - Phone: 586.323.1181
www.accutechmeasurement.com

Location of the **FULL LAYOUT MEASUREMENT FEATURES** on the part.

Customer: YOUR CUSTOMER NAME (YOUR COMPANY NAME)

Part Name: PART NAME INSERTED HERE

Part #: PART # INSERTED HERE

Job #: **YOUR JOB # HERE**

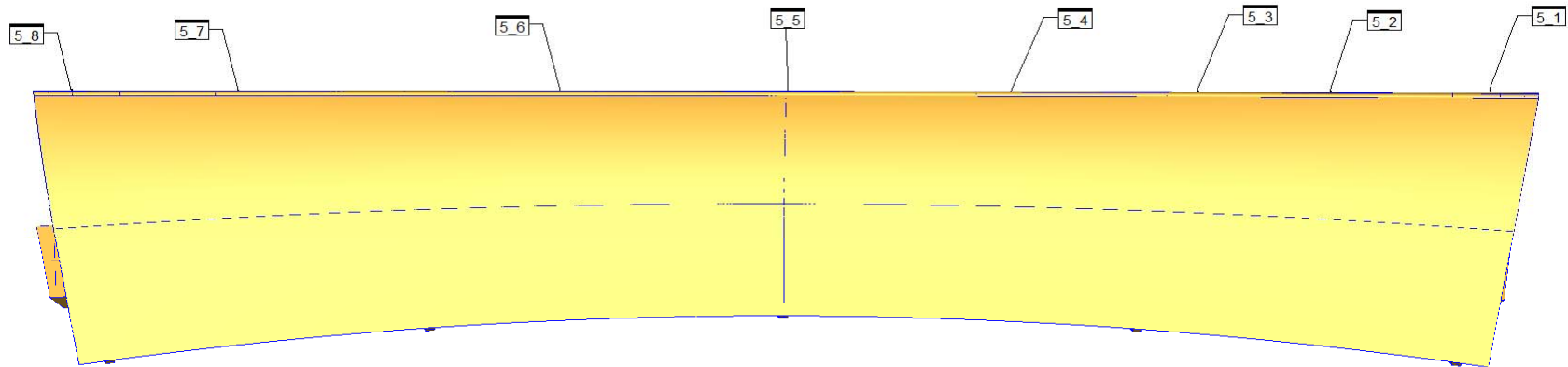

"A Revolution in the Dimensional Inspection Service Industry."

ISO 17025-2005 Certified - A2LA Accredited Laboratory



ACCU-TECH, INC.

43718 Utica Road
Sterling Heights, MI - Phone: 586.323.1181
www.accutechmeasurement.com

Location of the **FULL LAYOUT MEASUREMENT FEATURES** on the part.

Customer: YOUR CUSTOMER NAME (YOUR COMPANY NAME)

Part Name: PART NAME INSERTED HERE

Part #: PART # INSERTED HERE

Job #: **YOUR JOB # HERE**

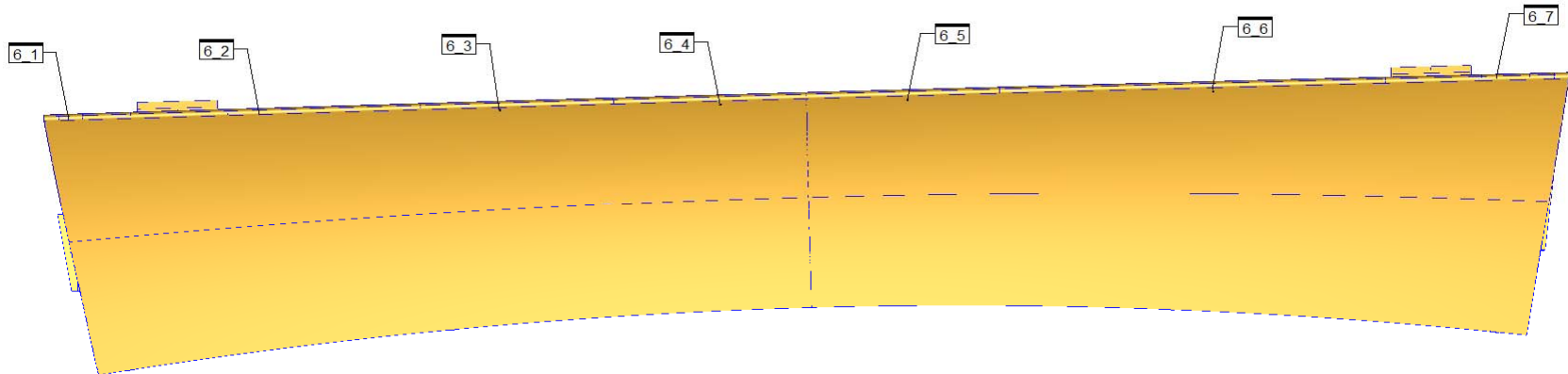



ACCU-TECH, INC.

43718 Utica Road
Sterling Heights, MI - Phone: 586.323.1181
www.accutechmeasurement.com

Location of the **FULL LAYOUT MEASUREMENT FEATURES** on the part.

Customer: YOUR CUSTOMER NAME (YOUR COMPANY NAME)

Part Name: PART NAME INSERTED HERE

Part #: PART # INSERTED HERE

Job #: **YOUR JOB # HERE**

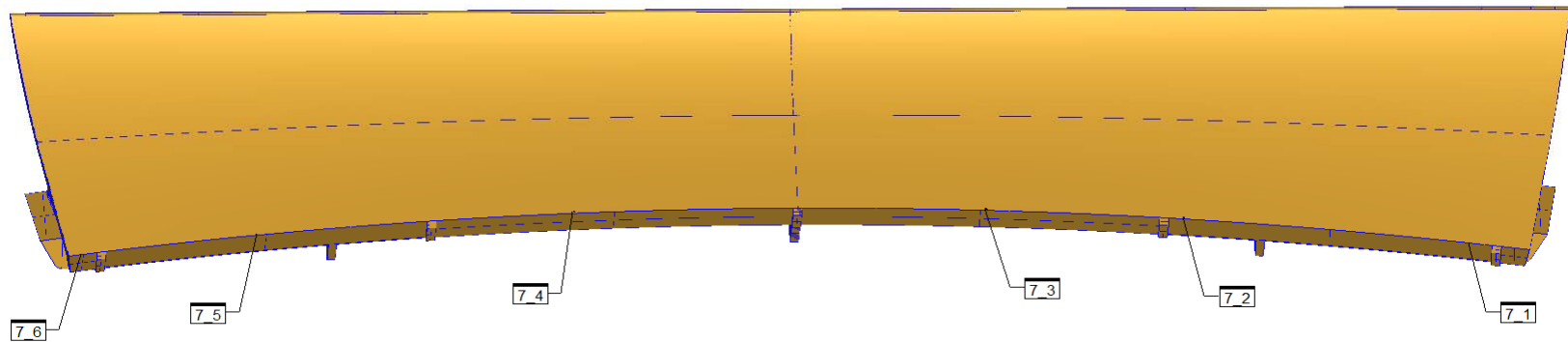

"A Revolution in the Dimensional Inspection Service Industry."

ISO 17025-2005 Certified - A2LA Accredited Laboratory



ACCU-TECH, INC.

43718 Utica Road
Sterling Heights, MI - Phone: 586.323.1181
www.accutechmeasurement.com

Location of the **FULL LAYOUT MEASUREMENT FEATURES** on the part.

Customer: YOUR CUSTOMER NAME (YOUR COMPANY NAME)

Part Name: PART NAME INSERTED HERE

Part #: PART # INSERTED HERE

Job #: **YOUR JOB # HERE**

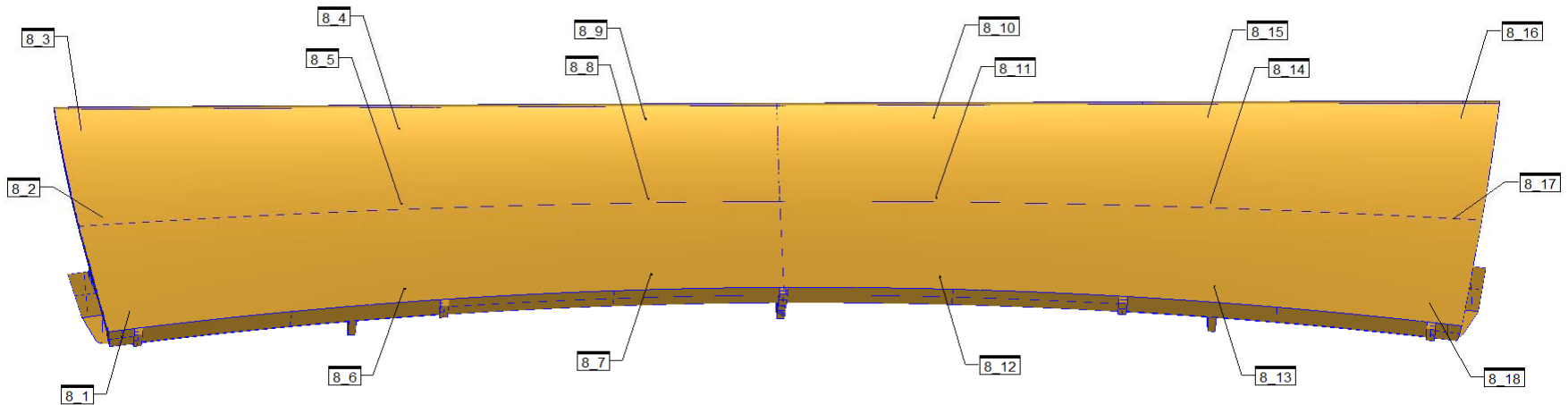

"A Revolution in the Dimensional Inspection Service Industry."

ISO 17025-2005 Certified - A2LA Accredited Laboratory